

**EGG BREAKING AND SEPARATING MACHINE CEM 108  
WITH AUTOMATIC LOADING TABLE CEO 108**

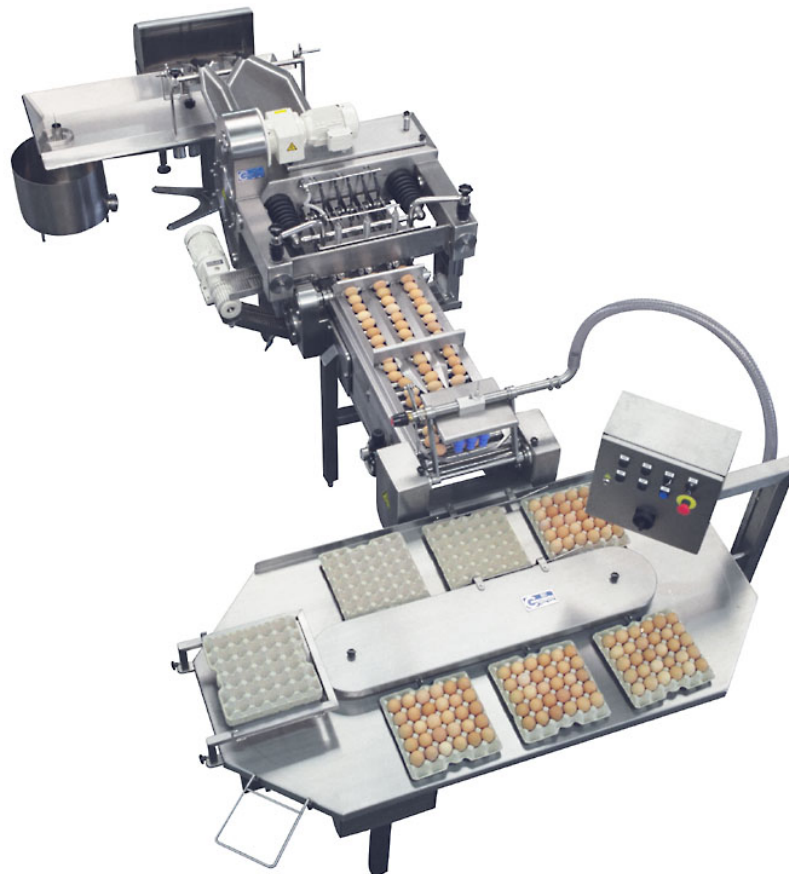

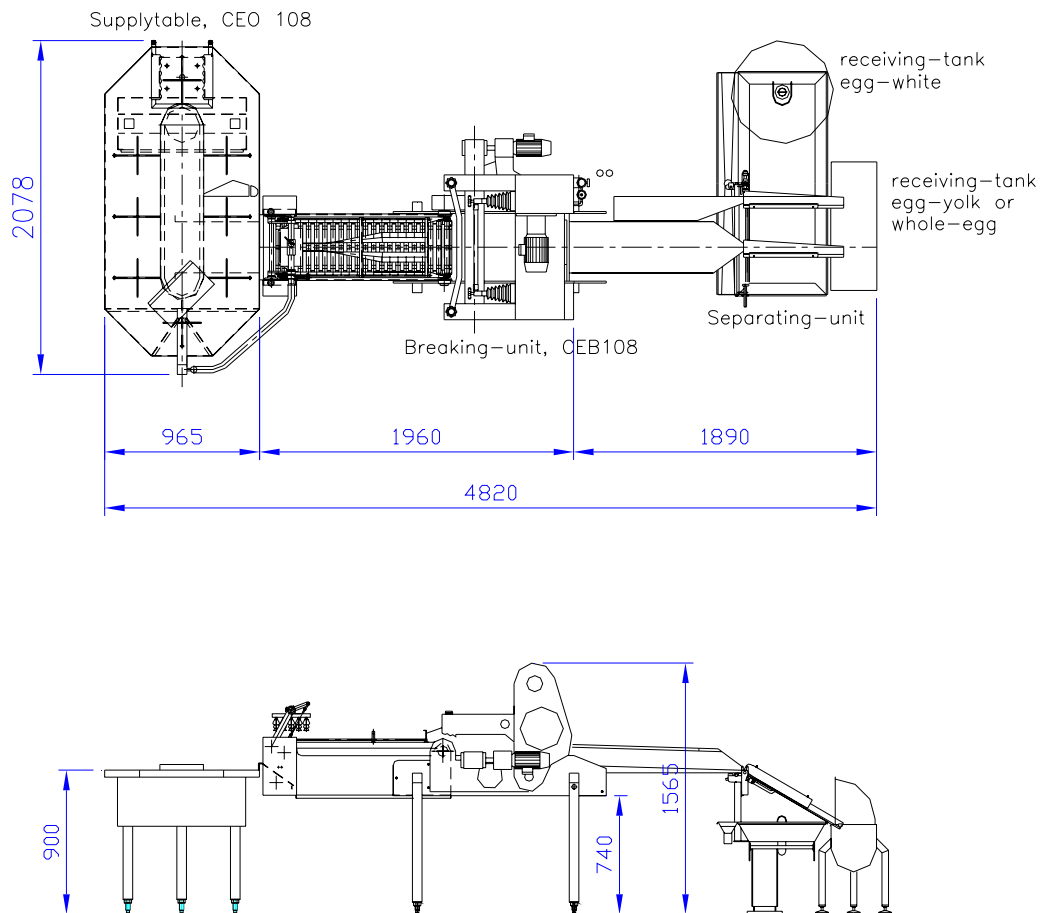

## TYPE: CEM 108

Capacity:	2.700 up to 10.000 eggs per hour
Electricity:	3ph. 400V+N+PE 1.3kW
Air consumption:	250L/min @ 5-6 bar
Cold water:	1L/min