

EGG BREAKING AND SEPARATING MACHINE CEM 216 WITH AUTOMATIC LOADING TABLE CEO 216

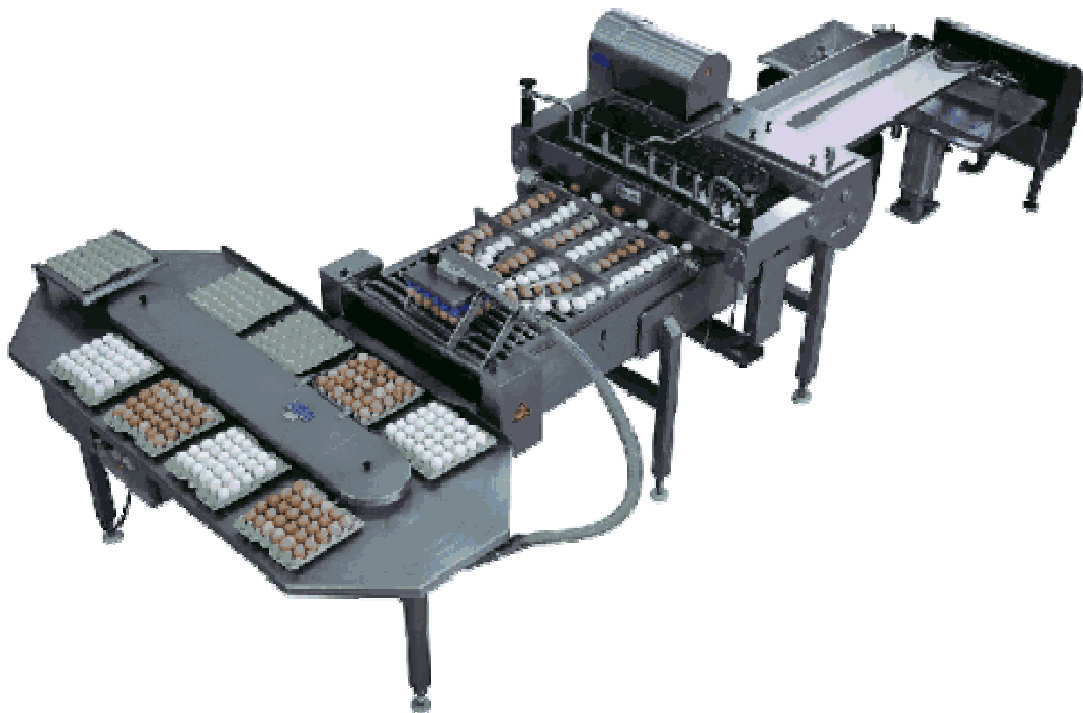

CEM216: with an adjustable capacity from 5.400 up to 21.600 eggs per hour

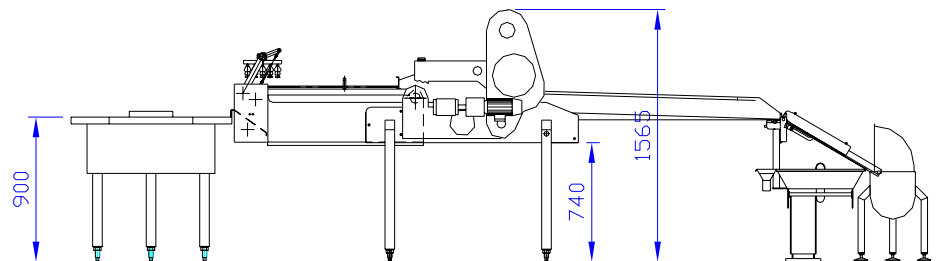
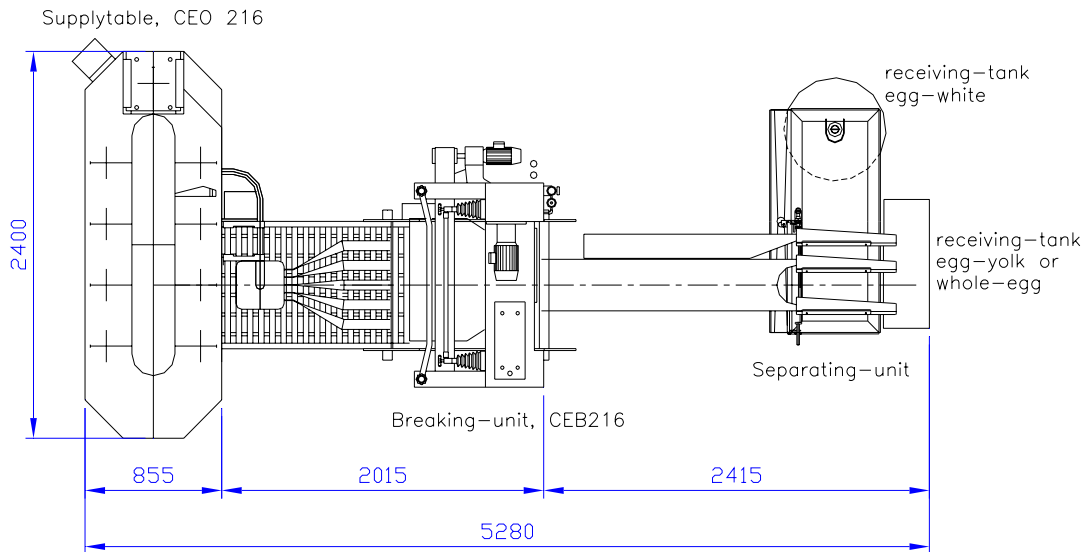

TYPE: CEM 216

Capacity: 5.400 up to 21.600 eggs per hour

Electricity: 3ph. 400V+N+PE 1,3 kW

Air consumption: 400L/min @ 5-6 bar

Cold water: 1L/min

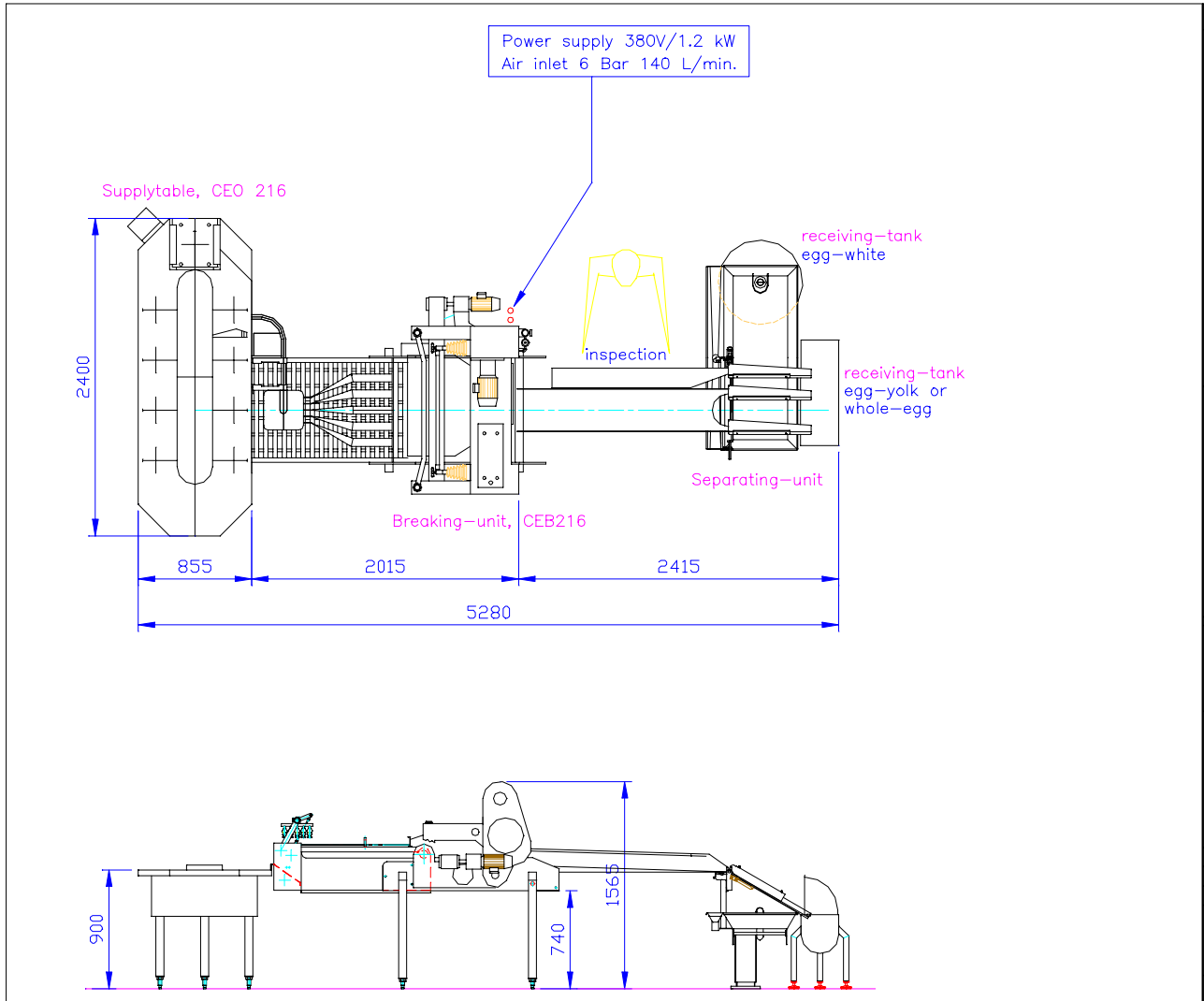

Technica
Egg Breaki M Continu Filters and Tube or Hom I.I.T.S.T., batch Spray Dry Aseptio L Egg S C.I.P. Laborato All Auxili
 BILKSKE 93 BI Tel: +32 Fax: +32 e-mail: ovob@ovobel.com
Date: 30/10/2000 Drawn By: F. De Checked By:
Project: OVOBEL
Filename: A1hor.dwg