

## EGG BREAKING AND SEPARATING MACHINE CEM 216 WITH AUTOMATIC LOADER CAL216-1

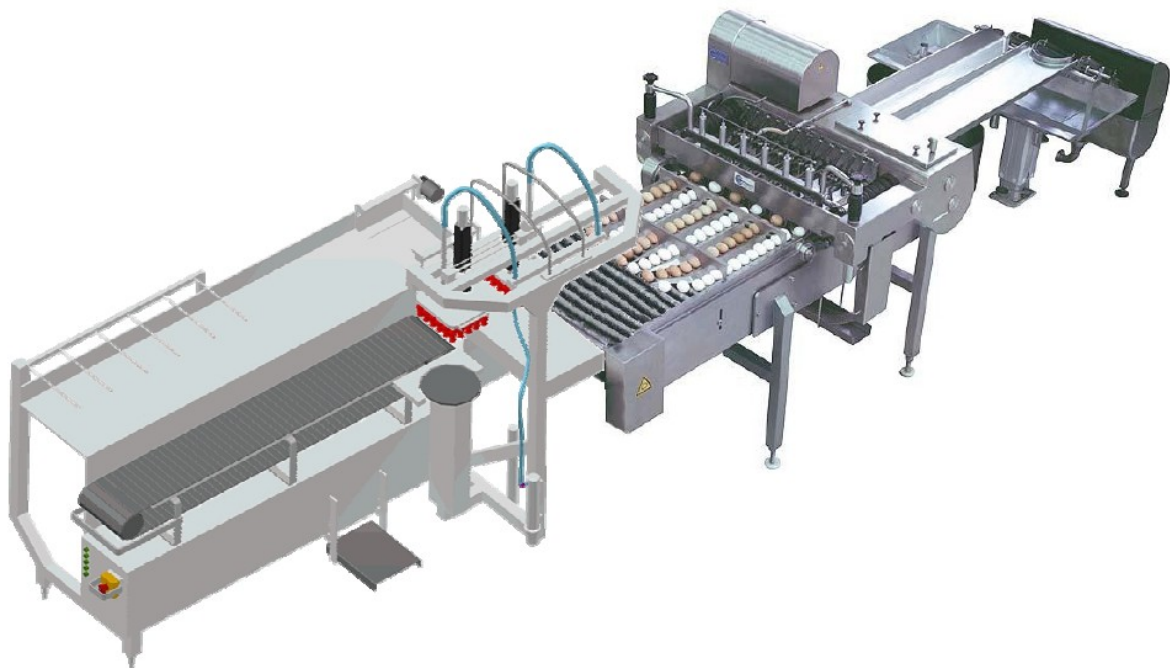

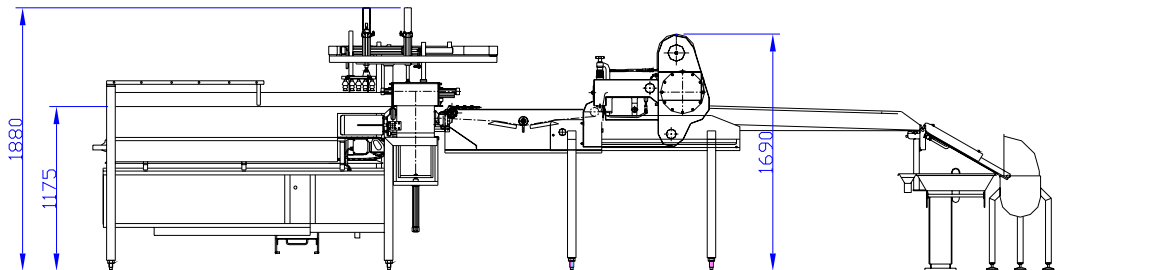
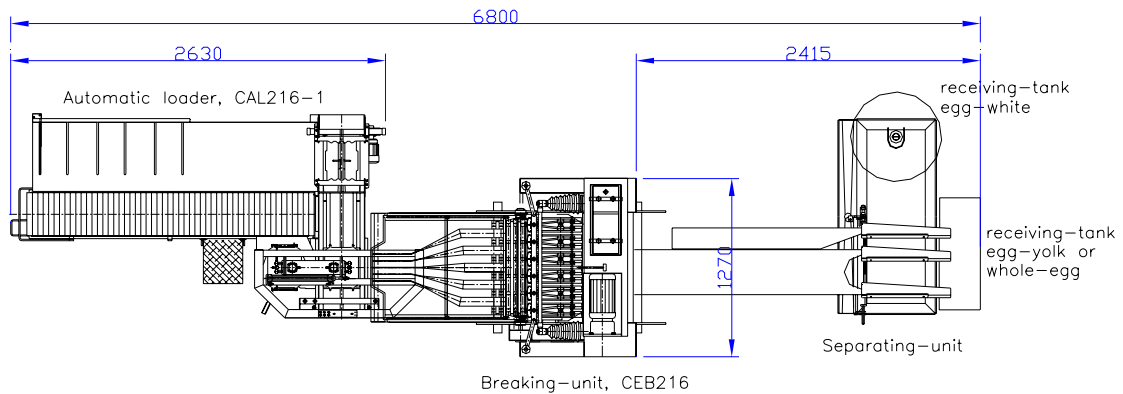

## TYPE: CEM 216 + CAL 216-1

Capacity:	5.400 up to 21.600 eggs per hour
Electricity:	3ph. 400V+N+PE 1,91 kW
Air consumption:	500L/min @ 5-6 bar
Cold water:	1L/min