

**EGG BREAKING AND SEPARATING MACHINE CEM 432  
WITH AUTOMATIC LOADER CAL216-2**

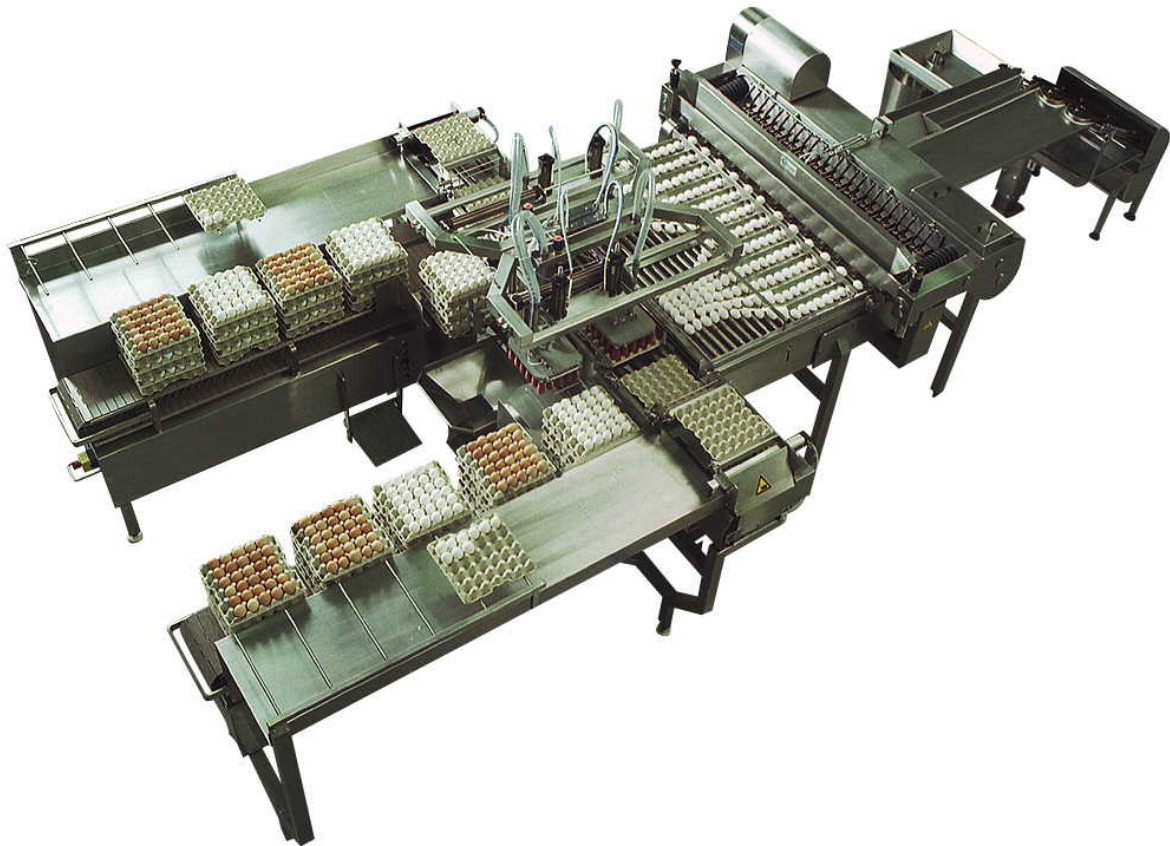

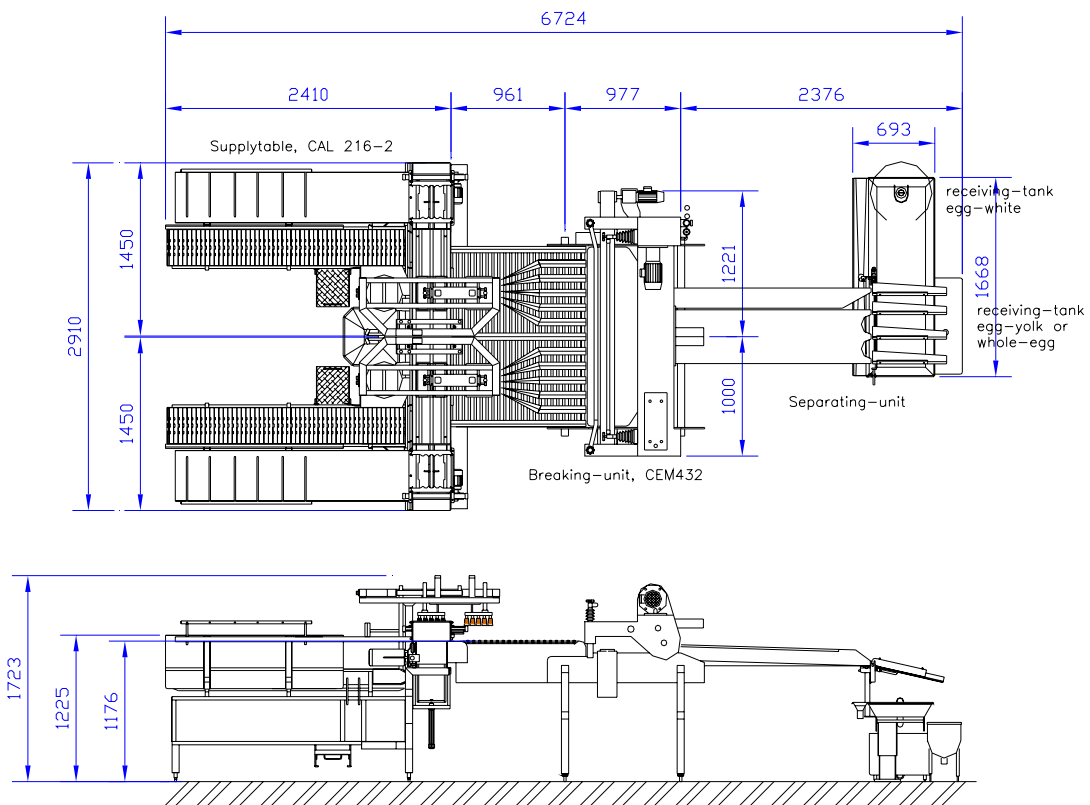

## TYPE: CEM 432 + CAL 216-2

Capacity: max. 43.200 eggs per hour

Electricity: 3ph. 400V+N+PE 2,16 kW

Air consumption: 600L/min @ 5-6 bar

Cold water: 1L/min